

LBS
conveyor belts

CUSTOM MADE
with passion!



INNOVATIVE LIGHT-DUTY SCRAPER

endless in service and innovation

The right combination leads to SUCCESS!

Whether sticky pizza dough or creamy chocolate mass, whether as a head scraper in a brickyard or in particularly hard use in a mine: In practice, our wipers have proven their worth especially when existing solutions have only delivered unsatisfactory results. Problematic goods with tough material properties are particularly well separated from the conveyor belt or transport roller by the flexible polyurethane lip. Unevenness on the surface of the conveyor belt is compensated without any problems, without negatively affecting the scraping result. Our belt scrapers have already proven their value in practice in the following areas, among others:

Vegetable processing
Potato processing industry
Waste water treatment
Brick production
Pizza production
Chocolate and sweets industry

Meat processing industry
Industrial bakeries
Paper recycling
Cement industry
Waste water treatment
Sugar refinery



The Applications



- » Strongly adhering residues, such as fats, are easily removed.

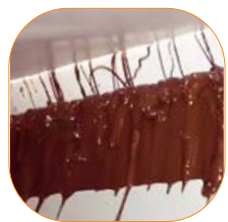

- » Heated scrapers ensure easy stripping of creams and chocolate.



- » Heavy and sticky materials are stripped off without difficulty.



- » Even with modular conveyors, the scraper nestles tightly and flexibly to the surface of the conveyor.

Special problems - Special solutions

We offer custom made scrapers. Based on your specifications, we develop and produce custom scrapers quickly – optimised to meet local requirements.

We offer custom-made products with specific material heights and widths tailored to individual requirements, which are optimal for the respective application:

- » temperature-resistant (-20°C to +60°C / +250°C; resp. - 4°F to 140°F / 480°F)
- » heatable scrapers equipped with interior heating e.g. for chocolate, grease, tallow.
- » antistatic scrapers for explosion hazardous areas
- » Materials according to the guidelines:
Regulation (EC) No. 1935/2004 | No. 10/2011

ATEX-compatible

- » scrapers in a reinforced version, for belt widths up to 2.500 mm

CARE AND MAINTENANCE

Without additional tools

To clean the scraper, it is swung away from the conveyor (against the tension direction) using the integrated lever without the need for additional tools.

Easy removal of remaining products

Product residue is easy to remove with a damp cloth or soft spatula.

Compliance with the highest hygiene standards.

No corners or edges!
This makes our scrapers easy and problem-free to clean.

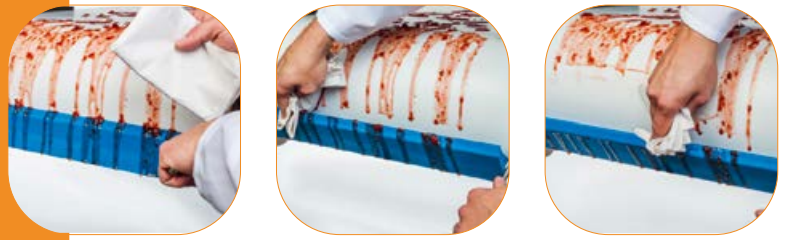

SIMPLE INSTALLATION

The sophisticated and space-saving design of our belt scrapers enables fast and cost-effective installation, even in existing systems. Our belt scrapers can be mounted as standard scraper (2-4) on the deflection roller or as an universal scraper in the lower section of the conveyor (1). Even under difficult conditions, such as tight spatial conditions, retrofitting is usually possible without any problems. The positioning of the scraper depends on the conveyed goods and the further use of the stripped product.

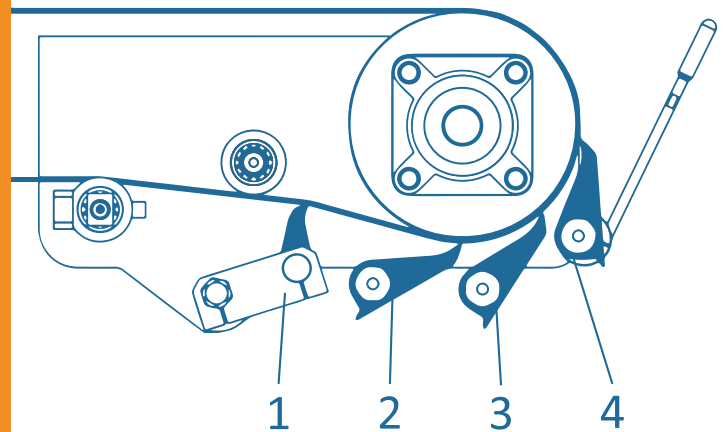

If the stripped product is to remain in the goods flow and be conveyed further, a standard scraper is recommended. If the stripped product is to be separated from the main stream, a universal scraper is recommended to be selected. This is particularly suitable for difficult stripping material.

What normally takes up
a lot of time

- and is therefore
frequently omitted -

becomes child's play
with our scrapers!

*Fold down
Wipe
Ready!*



PROBEL[®]

hotcleat[®]
POWERED BY LBS

Ecocleat[®]
BY LBS

MultiCutter[®]
BY LBS

Synthetic conveyor belts
Rubber conveyor belts
Synthetic modular belts and chains
Drive, timing and round belts
Synthetic gauze belts
Special endless belts
Components for belt conveyors
Technical rubber and synthetics
Service, installation and maintenance



endless in service and innovation



LBS
conveyor belts
CUSTOM MADE
with passion!

LBS Conveyor Belts BV
Phileas Foggstraat 48
NL-7825 AL Emmen
The Netherlands

Phone +31 (0)591 668220
Fax +31 (0)591 668239
Internet www.lbs.cc
E-mail info@lbs.cc

The text and material published in this brochure serve a purely informative purpose, and have no official or legal status in the form they are published here. For further information please contact us.

01.564.935-Version 1