

# Traxon CDMP

Quality Monitoring and Reporting Based on Cargo iQ Specifications

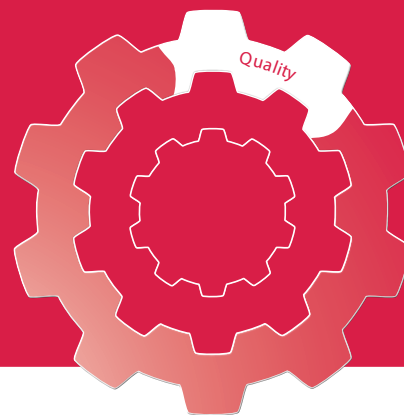

Cost efficiency and service quality are top priorities in the airfreight industry. Process optimization plays an important part in achieving these goals. Cargo iQ has specified globally accepted standards based on the defined Master Operating Plan (MOP) for quality management in air cargo business. CHAMP's Traxon CDMP (Cargo Data Management Portal) is an intelligent and intuitive tool to measure performance and initiate process improvements, making Cargo iQ certification easier.

## Benefits

- Improves supply chain visibility
- Identifies areas for process improvement
- Ensures timeliness and accuracy of data
- Pinpoints shipping and messaging failures
- Enables corrective action via alerts
- Enables real-time recovery to meet service commitments
- Measures shipper's KPIs
- Allows time-definite services to be delivered reliably
- Reduces operating costs
- Facilitates quality optimization according to Cargo iQ standards
- Helps with eAWB and the move to paper-free processes
- Proven solution: Monitoring about 50 % of Cargo iQ shipments

## Transparency and process improvements raise customer satisfaction

Traxon CDMP empowers airlines and forwarders to measure the performance of air cargo processes according to Cargo iQ standards and beyond. The service can be customized to meet individual business needs and further drive improvements. It helps to identify process weaknesses and pinpoint improvements needed to enhance performance and customer satisfaction.

Traxon CDMP connects different participants of the air cargo supply chain, increasing transparency, reducing the time and money spent on manually tracking shipments and improving the management of service failures. Fewer service incidents help improve consistency, which enable planning and workloads to be carried out more effectively. Traxon CDMP drives "delivered as promised" performance, which results in cost savings and a better service quality leading to reduced claims and creating opportunities for revenue growth.

## Simpler Cargo iQ certification

Traxon CDMP is CHAMP's solution for straightforward Airport-to-Airport (A2A) and Door-to-Door (D2D) Cargo iQ certification. Our knowledge and unparalleled experience facilitate quick customization and integration with a company's own IT system.



## Features

- Shipment management on consignment basis
  - Route map creation
  - Route map monitoring and alerting
  - Extensive search criteria for consignments
  - Full messaging, discrepancies, and EHCs history
  - Optional FSR/FSA polling functionality
- Shipments management on flight basis
- Configuration
  - Customize milestones & offsets (down to station level), lanes, areas/regions/stations, EHCs, alerts, and many more.
- Automated reporting
  - Cargo iQ mandatory reports
  - Detailed analysis reports for corrective actions
- Sophisticated web-based application
- Optional customized data feed into external systems
- Optional advanced Track & Trace application based on Traxon CDMP data

# Traxon CDMP empowers airlines and forwarders to exceed Cargo iQ quality standards

### Monitoring shipments and corrective actions made easy

Traxon CDMP is a web-based service with an innovative architecture. Based on booking information and (configured) offsets, the application calculates efficient route maps and defines the planned times according to which Cargo iQ milestones should be met. It supports route map monitoring on consignment level as well as performance reports, including a cumulative history of actual performance versus planned. The application not only triggers alerts with errors such as if milestones are missed, but also proactively facilitates quick corrective action. Traxon CDMP also enables a "flight view" that allows airline to view and monitor all shipments related to a particular flight, which helps to simplify the handling process at stations.

Easy-to-read graphics and exception coding facilitate root cause analysis of failures. Monthly reports provide a comparison with other Cargo iQ members on a level playing field. The application generates mandatory Cargo iQ, as well as customer specific reports.

Traxon CDMP uses existing cargo messages and thereby reduces the need for expensive development, integration, or host system modifications. Messaging can take place via Traxon cargoHUB or a third party CCS. Traxon CDMP is also inter-CDMP-capable, allowing real time data exchange and total visibility between Cargo iQ partners using different applications.

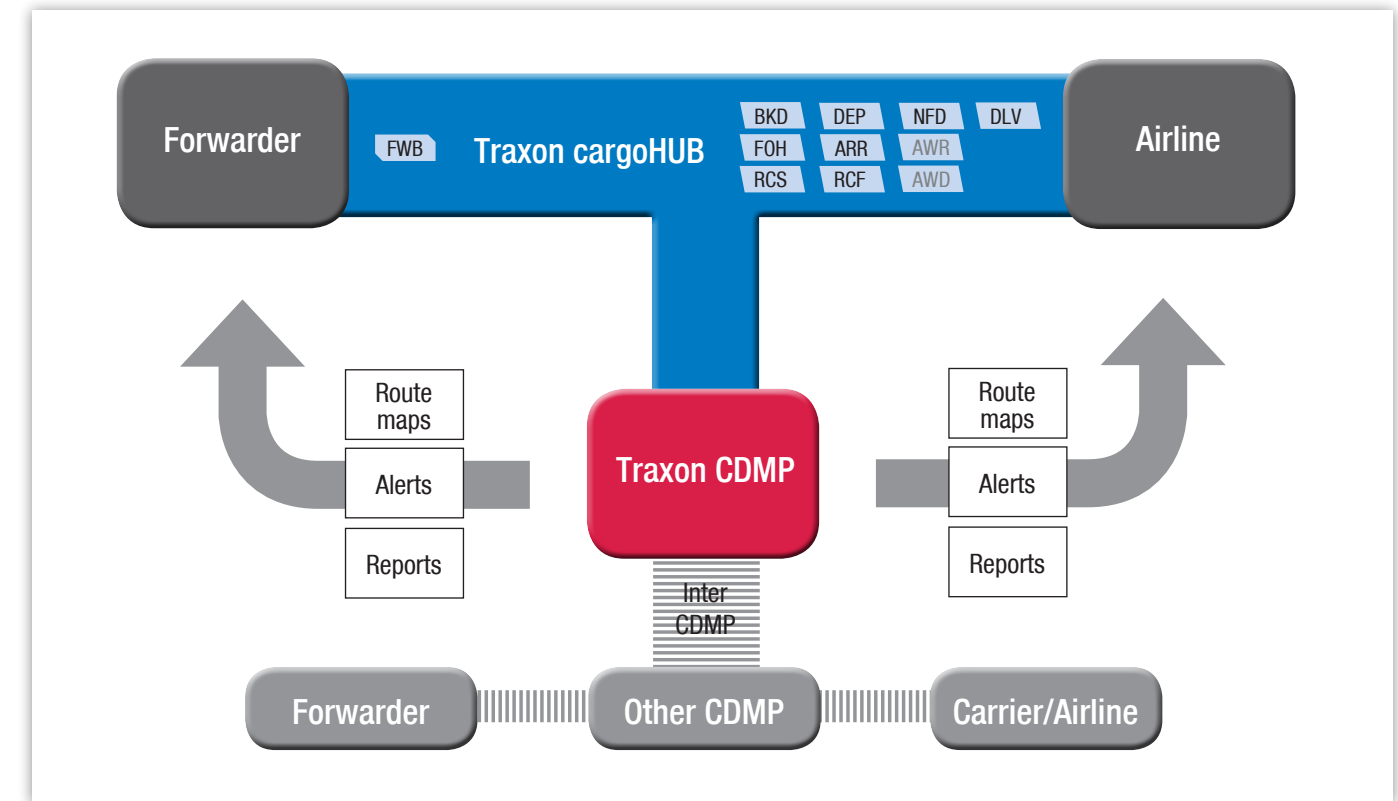

Traxon CDMP utilizes standard industry messaging for Airport-to-Airport route maps including FWBs (electronic AWB) and FSUs (status updates). For Door-to-Door customized messages can be flexibly defined between CHAMP and the freight forwarder.

## Step by step to process excellence

### Defining the route

Traxon CDMP uses Cargo iQ defined milestones to build a route map for a shipment. For Cargo iQ Airport-to-Airport the route map outlines a consignment's journey from origin to destination airport, based on service levels agreed with the forwarder. For Cargo iQ Door-to-Door, the route map shows a consignment's journey from pick-up location to origin airport and from destination airport to delivery point. By combining these route maps, Traxon CDMP provides a full visualization of a consignment's journey from door-to-door.

### Measuring performance using a common standard

Message updates (FSU) are sent when each milestone is completed. Traxon CDMP then checks operational performance against the planned milestones, updates the current status of the consignment, and notifies related partners of exceptions. In addition, Traxon CDMP also checks the timeliness of the messages reporting the operational performance. Based on the CDMP data, a track and trace tool can be embedded into an airline's or forwarder's own website or to be used as a mobile App. It provides shipment tracking information, as well as a visual representation of all Cargo iQ milestones and service failures.

<b>FWB</b> [-125] [0]	<b>LAT</b> [-120] [0]	<b>RCS</b> [-120] [0]	<b>DEP</b> [60] [0]	AAA-BBB	<b>ARR</b> [0] [0]	<b>RCF</b> [120] [0]
P 05 Sep 18:55 A 05 Sep 10:22	P 05 Sep 19:00	P 05 Sep 19:00 P 05 Sep 16:41	P 05 Sep 22:00 P 05 Sep 21:30	SD 05 Sep 21:00 EA 06 Sep 01:30	P 06 Sep 01:30	P 06 May 03:30 A 06 May 05:00

<b>DEP</b> [60] [0]	BBB-CCC	<b>ARR</b> [0] [0]	<b>RCF</b> [540] [0]	<b>NFD</b> [600] [0]	<b>AWD</b> [600] [0]	<b>DLV</b> [5760] [0]
P 06 Sep 22:00 A 06 Sep 21:12	SD 06 Sep 21:00 EA 07 Sep 16:51	P 07 Sep 16:51 A 07 Sep 09:33	P 08 Sep 01:51 A 07 Sep 09:33	P 08 Sep 02:51	P 08 Sep 02:51	P 11 Sep 16:51

CHAMP plays an integral role within Cargo iQ, recently engaging in specifications rewrite and the Master Operating Plan review group.

Each route map is visualized on-screen with different colors showing the status of each milestone: green = success; red = failure; blue = planned



# Our Portfolio

CHAMP Cargosystems provides the most comprehensive range of integrated IT solutions and distribution services for the air cargo transport chain. The portfolio spans Cargo Management Systems, messaging and integration services through our Community Integration Platform and a comprehensive suite of eCargo solutions. These include applications to meet customs and security requirements, quality optimization as well as e-freight and mobility needs. The products and services are well known under the Cargospot, Traxon, and Logitude brands.

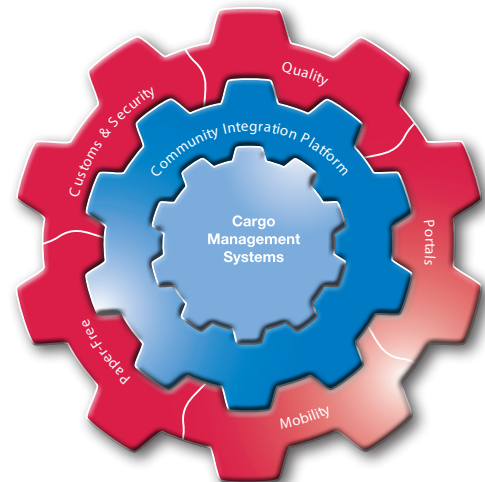

## The CHAMP Global Community

CHAMP serve over 200 airlines and GSA and connects these with some 3,000 forwarders and GHA. Our global community ranks among the largest in the industry. The size and combined expertise of the CHAMP global community allows us to leverage economies of scale to the benefit of all.

Traxon CDMP is available for airlines and forwarders.

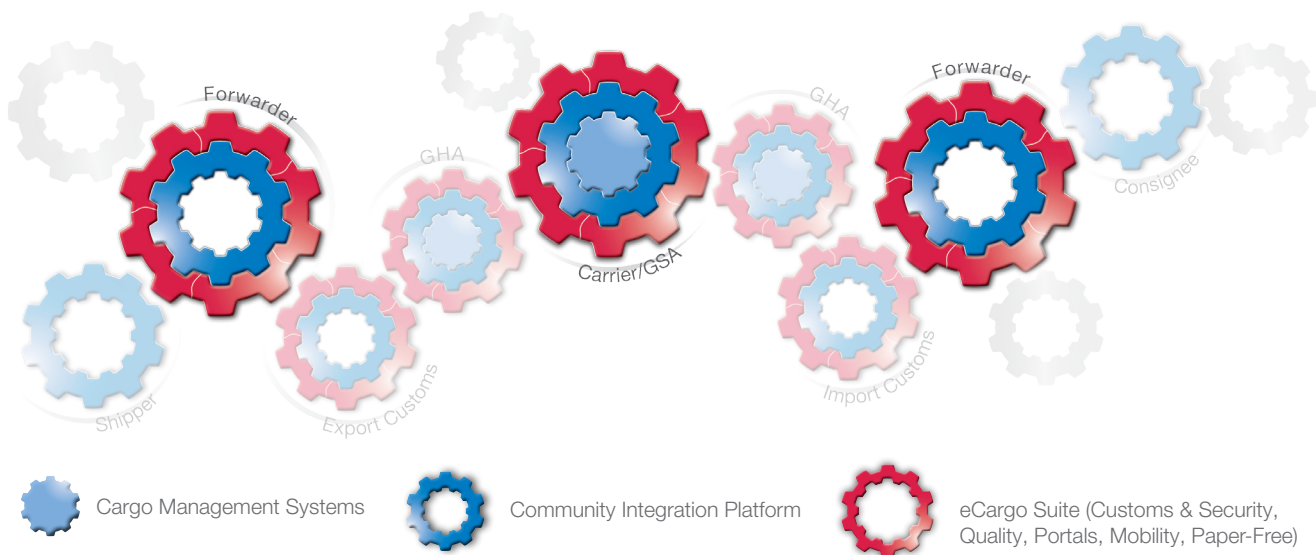

**About us:** CHAMP Cargosystems was founded in Luxembourg in 2004 as a 100 % subsidiary of Cargolux Airlines. In January 2005, CHAMP was merged with SITA Cargo (UK) Ltd. Only three years later, we acquired Softair AG and the acclaimed Cargospot portfolio. The company expanded rapidly and in 2010 opened a development center and operational office in the Philippines. In November 2011, we took over Traxon Europe, a provider of leading edge electronic communication solutions. Some 500 people are now working for CHAMP all over the world. We provide global solutions delivered locally to you. For further information see: [www.champ.aero](http://www.champ.aero) **CONNECTED THINKING FOR THE AIR CARGO COMMUNITY**

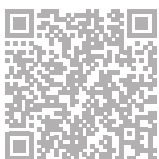

Global Headquarters  
 CHAMP Cargosystems S.A.  
 Lux Tech Center building  
 2, rue Edmond Reuter  
 Zone d'Activités « Weiergewan »  
 L-5326 Contern

Grand Duchy of Luxembourg  
 Tel: +352 268 16 100  
 Fax: +352 268 16 401  
 e-mail: [info@champ.aero](mailto:info@champ.aero)  
[traxonsales@champ.aero](mailto:traxonsales@champ.aero)

[www.champ.aero](http://www.champ.aero)

CHAMP®, CHAMP Cargosystems®, Cargospot® are registered trademark rights owned by CHAMP Cargosystems S.A., Traxon® is a registered trademark right which is used with the consent of the owner. Specifications subject to change without prior notice. This literature provides outline information only and (unless specifically agreed to the contrary by CHAMP Cargosystems in writing) is not part of any order or contract.

