

Our Closing File is made from cement reinforced with natural synthetic fibers (PVA), with rustic finish inorganic pigments which are used for its colouration.

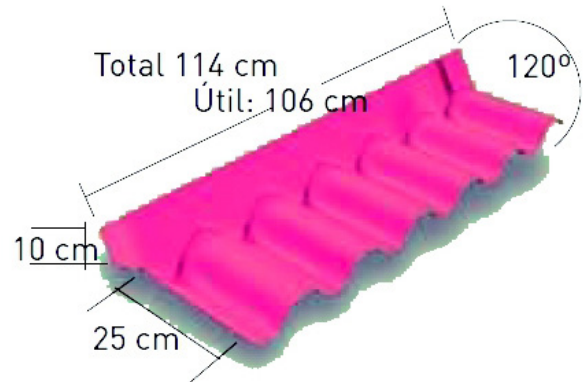

TECHNICAL DRAWING

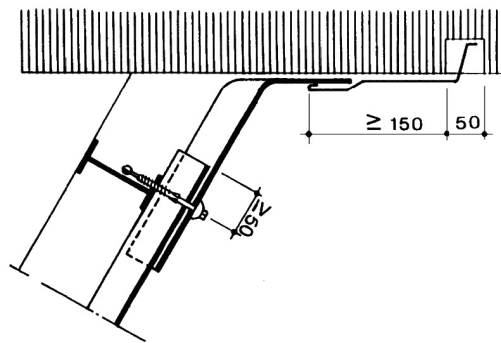

All measurements in this technical drawing are in millimetres (mm)

SIZES

At Tubex, we manufacture a collection of fibre cement products, however if we do not have the size you are requiring for your project, then we will be able to provide you with a specialist quotation to best suit your projects needs.

COLOURS AND FINISHES

Take a look at the different finishes and colours which we can produce our this product in.

STANDARD



NATURAL GREY

OTHER



RUSTIC

APPLICABLE REGULATIONS

 Classification: EN 494 (Asbestos free)

 Use according to UNE Standard 88111

 Metallic Fixings: UNE 88121

 Tightness: UNE 88122

 Cut on Site: UNE 412



SPECIFICATIONS

Length	1.14 cm
Wings Length	Overlap: 25 cm, Delivery: 10 cm
Nominal Plate Thickness	6.5 - 7 mm
Dimension Tolerance	According
Reaction To Fire	Class A1 UNE-EN13501
External Fire Behaviour	According
Heat / Rain / Snow Resistance	According
Weight	5 Kg