

Catenary Kit (CTI)



The Catenary kit lets you create a safe and stable structure by tensing horizontal cables between two points.

FEATURES / BENEFITS

- The light duty 3 mm version is ideal for suspending lightweight electrical services, ductwork and signage - up to 30 kg per free span
- The heavy-duty 6 mm version is perfect for suspending Electrical or HVAC services, or where a long catenary is required - up to 100 kg per free span
- Supplied as complete, ready-to-use kits, including galvanised wire rope
- Cut to bespoke lengths, hex locking key and release key included
- Fast installation, reducing time spent working at height
- Quarter turn locking mechanism in the Lockable Plus fastener prevents dynamic movements
- Easily tensioned using the Catenary Tensioning Tool

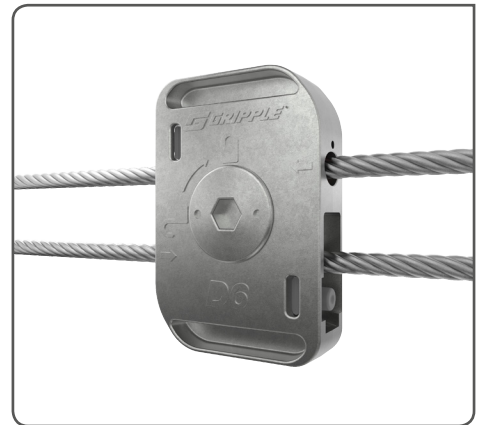

INSTALLATION & ADJUSTMENT

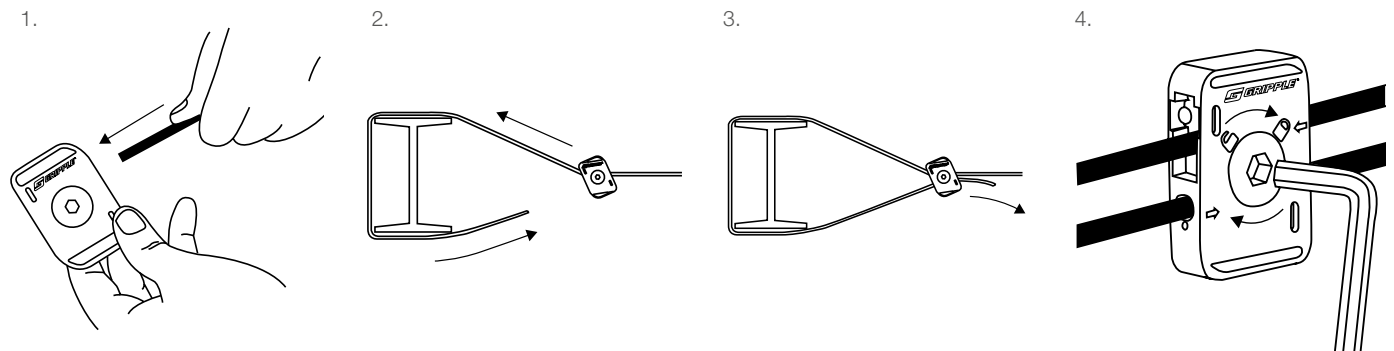

SPECIFICATION

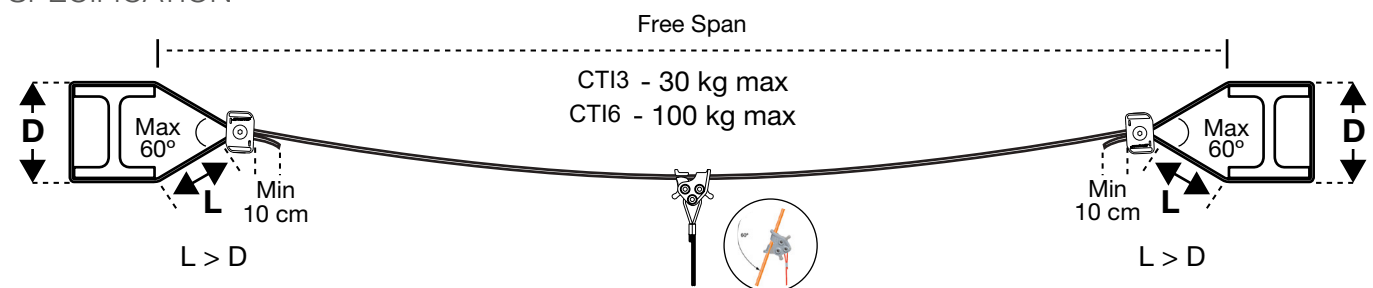

SUBMITTAL INFORMATION

Load Rating:

- CTI3 - up to 30 kg vertical load per free span
Connection type: 3 mm C-Clip
Not suitable for use with any Tensioning Tool
- CTI6 - up to 100 kg vertical load per free span
Connection type: 6 mm C Clip
Can be used with the Torq Tensioning Tool

Material:

Ceramic rollers and stainless springs for optimum corrosion resistance

Wire Rope Specifications:

- 3 mm - Galvanised 7 x 7
- 6 mm - Galvanised 7 x 19

RELATED PRODUCTS

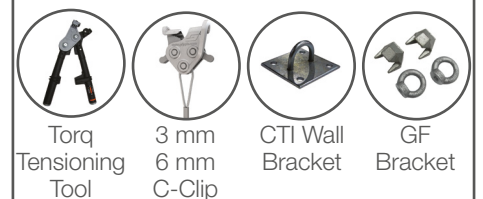

For more options on available products please contact us or visit www.gripple.com