

A universal wire rope suspension product designed for the fast suspension of cable containment, HVAC systems including multi-tier installations.

FEATURES / BENEFITS

- **Quick** – up to 6 times faster than traditional suspension systems
- **Safe** – can be pre-installed to channel, reducing time working at height
- **Easy** – integral ergonomically designed release button allows for simple adjustment
- **Secure** – button acts as a locking screw and indicator clearly highlights the wire is locked in position for ultimate security
- **Versatile** – variety of foot attachments available to suit applications
- **Strong** – highest load rating capability to date; up to 250 kg with 5:1 SWL



INSTALLATION & ADJUSTMENT

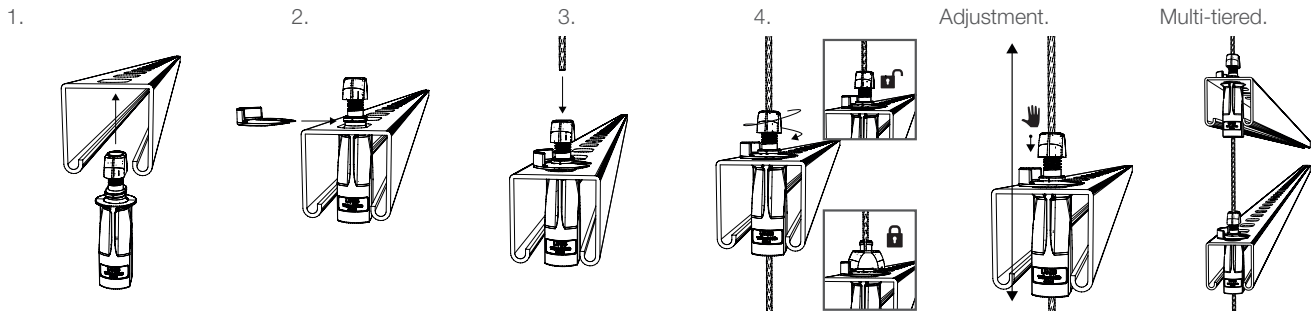

Maximum off axis suspension = 15° (unless otherwise specified by Gripple Technical Services)

SPECIFICATION

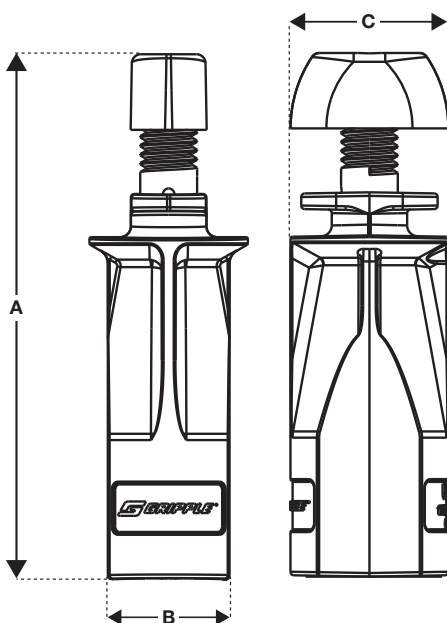

No. 2	Dimension	A	B	C
	mm	55	17	20

No. 3	Dimension	A	B	C
	mm	73	17	22

No. 4	Dimension	A	B	C
	mm	115	22	30

AVAILABLE END FIXINGS

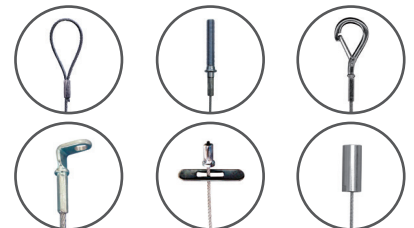

For more options on available end fixings please contact us or visit www.gripple.com

SUBMITTAL INFORMATION

Load Rating:

No. 2 - 55 kg @ 5:1
No. 3 - 110 kg @ 5:1
No. 4 - 250 kg @ 5:1

Material:

Housing – Type ZA2 Zinc
Carriage – Acetal Copolymer
Wedge – Sintered steel hardened to min. 56 Rockwell C
Button – Acetal Copolymer
End Cap – PP (Polypropylene)
Retention Clip – PP (Polypropylene)